

BW4c-CTM (CE/UL)

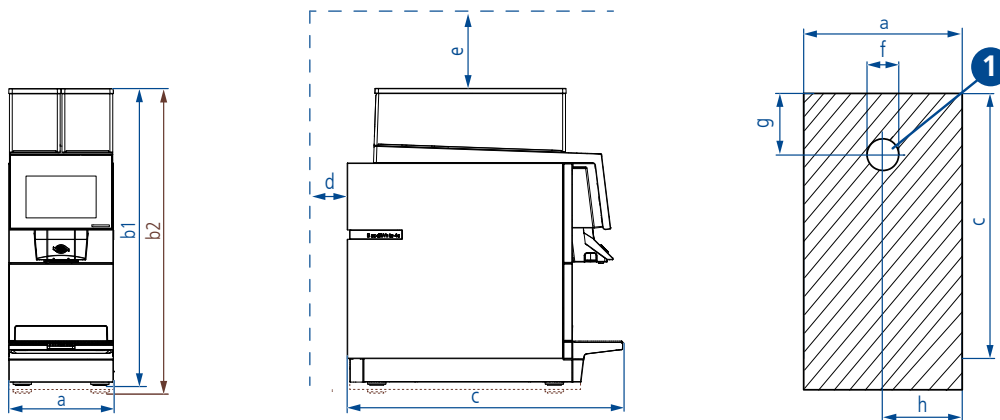

1 Hole diameter 70 mm / 2.75 in for water / milk inlet / water drain / sensor cable / power cable etc.

a	228 mm / 8.97 in	c	600 mm / 23.62 in	f	70 mm / 2.75 in
b1	CE: 646 mm / 25.43 in (feet: 57 mm / 2.24 in) or optional 676 mm / 26.61 in (feet: 87 mm / 3.42 in)	d	50 mm / 1.96 in	g	150 mm / 5.9 in
b2	UL: 676 mm / 26.61 in (feet: 87 mm / 3.42 in)	e	350 mm / 13.77 in	h	114 mm / 4.48 in

Drain

- i: Distance of machine to drain < 1000 mm / 39.37 in.
- Drain line (hose) not sagging.
- No back pressure in the water line.
- The end of the line not submerged in water.

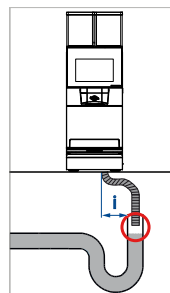

Refrigerator milk suction hose

- Max. length of refrigerator milk suction hose = 1200 mm / 47.24 in or 2200 mm / 86.6 in. Position the refrigerator close enough to the coffee machine.

Machine parameters		Water connection specifications	
Connection / power CE	220-240 VAC / 50-60 Hz 2700-3100 W / 12-13 A	Water supply	3/8"
Connection / power UL	208 VAC / 60 Hz 2700 W / 13 A	Dynamic water pressure	2-4 bar 30-60 psi
Outlet height	85 – 175 mm 3.34 – 6.88 in	Water boiler pressure	11.7 bar 169.6 psi
Weight	40 kg 88.18 lbs	Chlorine	None
		TDS	70-200 ppm
		Total hardness	5-8 °dH / 8-14 °fH
		pH	6.8-7.4
		Alkalinity	<100 ppm
		Iron	<0.25 ppm